

COMPT	DOORS	OPENING DIMENSIONS	INSIDE DIMENSIONS	VOLUME
L1	HINGED	22.75"W x 24.00"H	29.75"W x 59.00"H x 17.75"D	18.02 CU. FT.
L2	HINGED	51.50"W x 24.00"H	60.00"W x 28.25"H x 17.75"D	17.41 CU. FT.
L3	HINGED	17.75"W x 53.00"H	24.75"W x 59.00"H x 17.75"D	14.99 CU. FT.
L4	HINGED	42.00"W x 53.00"H	47.25"W x 59.00"H x 17.75"D	28.63 CU. FT.
A1	ROLL-UP	44.50"W x 20.50"H	53.00"W x 29.75"H x 47.75"D	43.57 CU. FT.

COMPT	DOORS	OPENING DIMENSIONS	INSIDE DIMENSIONS	VOLUME
R1	HINGED	22.75"W x 38.00"H	29.75"W x 45.00"H x 22.75"D	17.82 CU. FT.
R2	HINGED	50.00"W x 9.25"H	60.00"W x 14.00"H x 22.75"D	11.05 CU. FT.
R3	HINGED	17.75"W x 38.00"H	22.75"W x 45.00"H x 22.75"D	13.47 CU. FT.
R4	HINGED	42.00"W x 38.00"H	47.25"W x 45.00"H x 22.75"D	27.99 CU. FT.
TOTAL VOLUME				192.75 CU. FT.

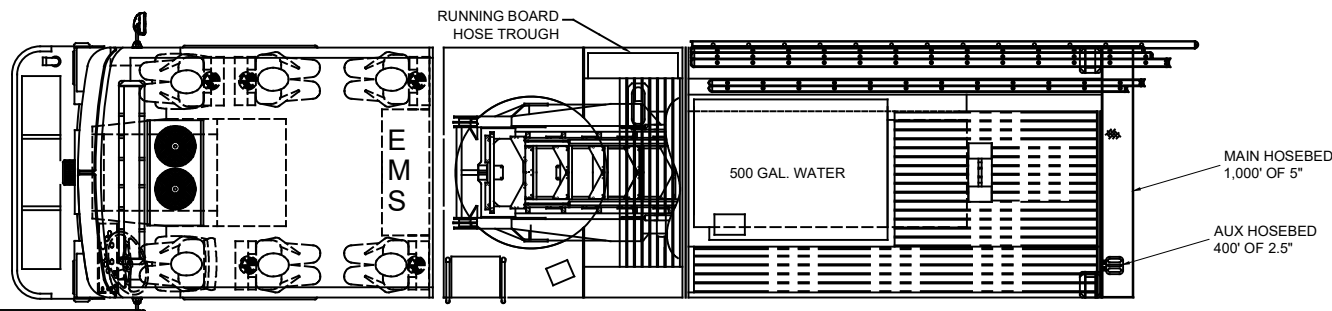

- DUO SAFETY CUSTOM LADDER COMPLIMENT
- 10' FOLDING (AERIAL)
- 14' ROOF (LADDER RACK)
- 14' ROOF (AERIAL)
- 24' 2-SECTION (LADDER RACK)
- 35' 3-SECTION (LADDER CHUTE)

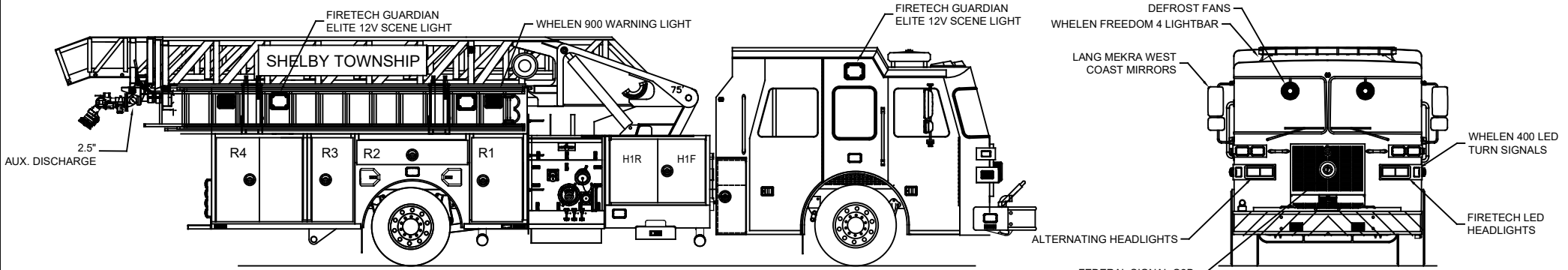
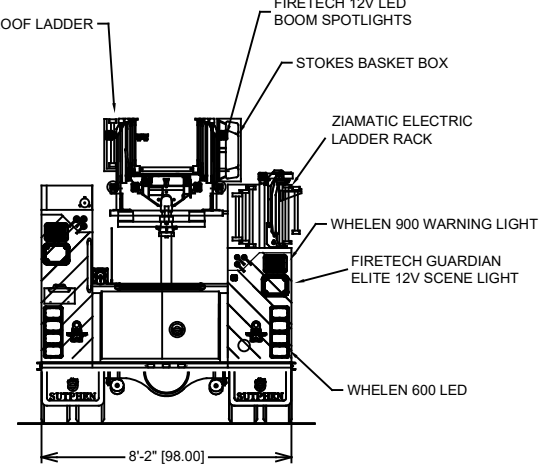
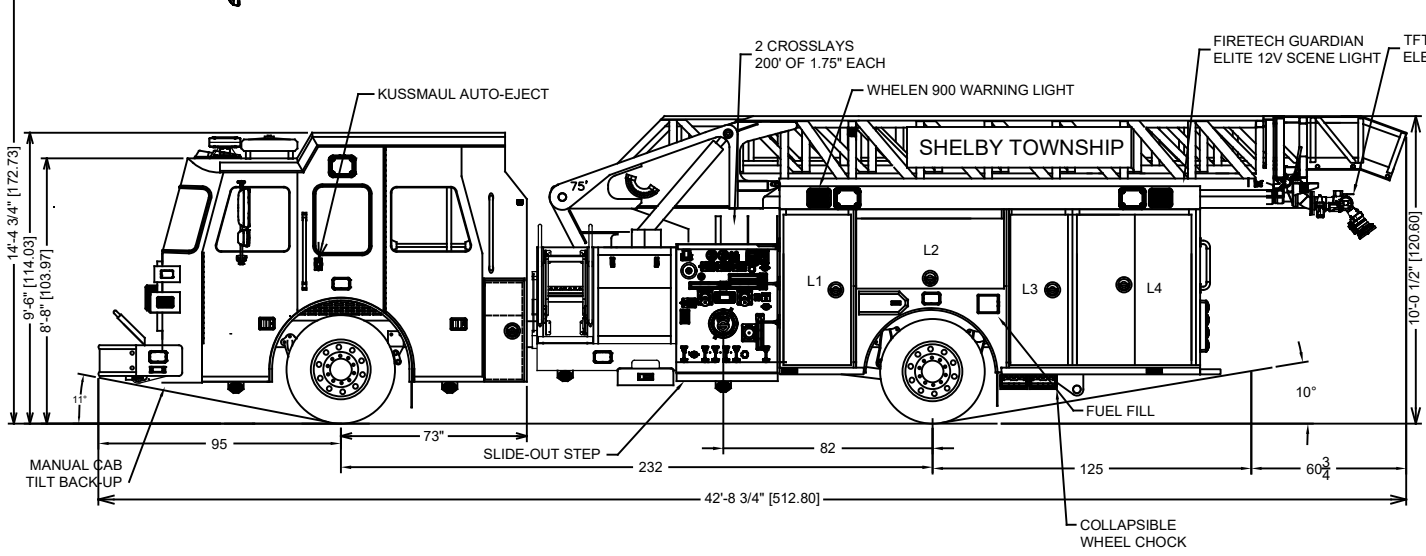

DIMENSIONS SHOWN ON THIS DRAWING ARE APPROXIMATE AND ARE SUBJECT TO MINOR DEVIATIONS DURING CONSTRUCTION.

IN THE EVENT OF A DISCREPANCY BETWEEN THE SUTPHEN SPECIFICATIONS AND DRAWING, THE SUTPHEN SPECIFICATIONS SHALL PREVAIL.

DRAWING IS FOR REFERENCE ONLY. SOME ITEMS PROPOSED MAY NOT BE SHOWN OR NOTED.

CUSTOMER APPROVAL		REV.	DESCRIPTION	BY	DATE
NAME:					
TITLE:					
DATE:					

DRAWN BY: CAM  
DATE: 11/21/2022  
MFG. FACILITY: HILLIARD

**SUTPHEN**

SHELBY TOWNSHIP FIRE DEPT.  
SHELBY TWP, MI

SL75  
HS-XXXX